



# WHITE PAPER

**TC010**

Issued  
Revised

December 3, 2012  
April 7, 2016

## Standard Product Safety Sign Catalog for Automotive Fire Apparatus

### RATIONALE

This document gives the fire apparatus manufacturers an option to provide standardized product safety sign text and artwork for common hazards.

### FOREWORD

This document presents safety signs for potential use on fire and rescue apparatus.

### TABLE OF CONTENTS

1	SCOPE.....	1
2	REFERENCES.....	1
3	DEFINITIONS .....	2
4	GENERAL .....	2
5	NFPA APPARATUS STANDARD COMPLIANCE .....	3
6	SAFETY SIGN TEXT AND ARTWORK.....	4

## 1 SCOPE

This document presents a standardized catalog of safety sign text and artwork that may be used by any apparatus manufacturer to warn of common hazards. It remains the product manufacturers' obligation to furnish adequate warnings and instructions, after consideration of the products specific characteristics and environment of use. A manufacturer may elect to use any of the standardized signs, text and/or artwork contained in this catalog, but no manufacture is required to do so.

## 2 REFERENCES

### 2.1 Applicable Publications

The following publications form a part of this specification to the extent specified herein.

#### 2.1.1 ISO Publications

Available from ANSI, 25 West 43rd Street, New York, NY 10036-8002, Tel: 212-642-4900, [www.ansi.org](http://www.ansi.org).

ISO 9244 Earth-moving machinery – Machine safety labels – General Principles

ISO 7010 Graphical symbols – Safety colours and safety signs – Registered safety signs

#### 2.1.2 Other Publications

ANSI Z535.4 American National Standard for Product Safety Signs and labels

ANSI Z535.6 American National Standard for Product Safety Information in Product Manuals, instructions, and Other Collateral Materials

NFPA 1901 Standard for Automotive Fire Apparatus

NFPA 1906 Standard for Wildland Fire Apparatus

### 3 DEFINITIONS

#### 3.1 Product Safety Sign

Sign, label, or decal affixed to a product that provides essential information concerning a potential hazard, the degree or level of hazard seriousness, the probable consequence of involvement with the hazard, and how the hazard can be avoided.

### 4 GENERAL

- 4.1 New proposals for product safety sign ideas should be forwarded to FAMA. The FAMA Product Safety Sign group will consider new ideas at each FAMA technical committee meeting and may add new text and artwork to this catalog as appropriate.
- 4.2 The product safety signs shown in this document are intended as examples for sufficiency of text and graphic size with respect to each hazard, however it is the product manufacturer's responsibility to determine the adequacy of warnings and/or instructions that are provided with the product.
- 4.3 Limitations inherent in some reproduction and display technologies may require increased line thickness or other minor modifications of symbols. Such modifications are acceptable provided the symbol is unchanged in its basic graphical elements and remains easily discernible by the operator.
- 4.4 To improve the appearance and perceptibility of a safety sign, or to coordinate with the design of the equipment to which the sign is applied, it may be necessary to change the line thickness or round the corners of a symbol. The graphic designer is free to make such changes, provided that the essential perceptual characteristics of the symbol are maintained.
- 4.5 Some of the product safety signs included in this document are provided with "textless" two-panel versions developed using the guidelines found in ISO 7010. Where appropriate, these versions could be used in place of the ANSI Z535.4 signs at the option of the manufacturer.
- 4.6 Symbols on controls and displays should have good contrast to their background. Pictorials may use either a light symbol on a dark background or a dark symbol on a light background at the manufacturer's discretion. When a pictorial image is reversed (for example, from black-on-white to white-on-black and vice versa), it should be done for the entire pictorial.
- 4.7 Where used, product safety signs should be located as close as practical to the location of the hazard addressed. Some recommendations regarding sign placement are included in this catalog.
- 4.8 Reference numbers are provided as a convenience to the organization of this document and need not appear on the final product.
- 4.9 Product safety sign graphic thumbnails are provided in this document. Full scale artwork can be downloaded from the FAMA website at [www.FAMA.org](http://www.FAMA.org).
- 4.10 All standard ISO version signs are 6.65 in. tall by 3.35 in. wide.
- 4.11 Font sizes are based on using Microsoft Sans Serif.









## 5 NFPA APPARATUS STANDARD COMPLIANCE

- 5.1 The following is a list of the safety signs in this document that specified in the 2016 editions of NFPA 1901 *Standard for Automotive Fire Apparatus* and NFPA 1906 *Standard for Wildland Fire Apparatus*:

Topic	1901	1906
Cab Seating Capacity	FAMA14	
Seat Belts	FAMA07	FAMA07
Seat Not to be Occupied	FAMA06	FAMA06
Fire Service Tire Rating	FAMA12	
Helmets	FAMA15	FAMA43
Equipment Mounting	FAMA10	FAMA10
Ultra High Pressure	FAMA20	FAMA20
Hose Restraint	FAMA22	FAMA22
Access Methods	FAMA23	FAMA23
Riding on the Tailboard	FAMA24	FAMA24
Pump Operator	FAMA25	FAMA25
Winch Receivers and Rope Anchors	FAMA28	FAMA28
Hazards from Stabilizer Motion	FAMA30 FAMA31 FAMA32 FAMA33	
Fall Restraint	FAMA34 FAMA40	
Aerial Electrocution from Power Lines	FAMA35 FAMA36	
Aerial Capacity	FAMA37	
Ladder Rung Pinch	FAMA38	
Aerial Inspection	FAMA39	
On-Board Pump and Roll		FAMA44 FAMA45
Aerial Device Pinch	FAMA46	
Aerial Operator Attention Required	FAMA47	







6 SAFETY SIGN TEXT AND ARTWORK

Ref Number	Hazard	Location	Size (in.)	Font Size	ANSI Version	ISO Version
FAMA01	Battery Explosion	Visible to personnel near batteries.	3.0 x 4.0	12		<p><b>FAMA01G</b></p>
FAMA02	Rotating Shafts	One sign each side of vehicle on the frame rail, and any other place where rotating shaft hazard is apparent.	3.0 x 4.0	14		<p><b>FAMA02G</b></p>
FAMA03	Hot Surface	Near hot surfaces	2.0 x 5.0	18		<p><b>FAMA03G</b></p>
FAMA04	Hot Exhaust - Horizontal Muffler	Visible to personnel approaching the hot exhaust parts.	3.5 x 3.5	14		



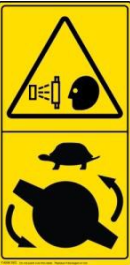







Ref Number	Hazard	Location	Size (in.)	Font Size	ANSI Version	ISO Version
FAMA05	Spinning Fan	Visible to personnel at each approach to spinning fans.	3.0 x 4.0	14	 <p><b>DANGER</b></p> <p>Fan Blades Spin without Warning. Keep hands, hair, and clothes away. Keep clear when motor is running. Spinning blades will injure or kill.</p> <p><small>FAMA05 Do not paint over this label. Replace if damaged or lost.</small></p>	 <p><b>FAMA05G</b></p>
FAMA06	Seats Without Belts Not Occupied	Visible to each occupant where seating positions without seat belts are present.	2.0 x 3.0	14	 <p><b>WARNING</b></p> <p>Crash Hazard This seat is not to be occupied while vehicle is in motion. Seats without belts are for use with vehicle parked only. Unbelted occupants are at greater risk of injury or death in a crash.</p> <p><small>FAMA06 Do not paint over this label. Replace if damaged or lost.</small></p>	 <p><b>FAMA06G</b></p>
FAMA07	Seated and Belted	Visible to any occupant.	2.0 x 3.0	9	 <p><b>WARNING</b></p> <p>Crash Hazard Occupants must be seated and belted when vehicle is in motion. Use only OEM approved belts. Unbelted occupants are at greater risk of injury or death in a crash.</p> <p><small>FAMA07 Do not paint over this label. Replace if damaged or lost.</small></p>	 <p><b>FAMA07G</b></p>
FAMA08	Swivel Seat Unsecured	Visible to occupant of swivel seat.	1.9 x 3.1	10	 <p><b>WARNING</b></p> <p>Seat Swivel Hazard Lock seat in position before vehicle is placed in motion. Unsecured seat will not protect occupant in a crash.</p> <p><small>FAMA08 Do not paint over this label. Replace if damaged or lost.</small></p>	 <p><b>FAMA08G</b></p>







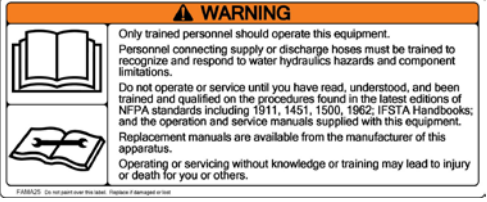

Ref Number	Hazard	Location	Size (in.)	Font Size	ANSI Version	ISO Version
FAMA09	Air Conditioning Refrigerant	On or near air conditioning unit where mechanic would be apt to find it.	2.0 x 5.0	10		<p><b>FAMA09G</b></p>
FAMA10	Cab Equipment Mounting	Visible to operator inside the cab.	2.0 x 3.0	8		<p><b>FAMA10G</b></p>
FAMA11	SCBA Seat Insert	Visible to operator inside the cab.	2.0 x 3.0	8		<p><b>FAMA11G</b></p>
FAMA12	Fire Service Tire Rating	Visible to operator inside the cab.	2.0 x 3.0	8		<p><b>FAMA12G</b></p>











Ref Number	Hazard	Location	Size (in.)	Font Size	ANSI Version	ISO Version
FAMA13	Electronic Stability Control	Visible to operator inside the cab.	2.0 x 3.0	10		<p><b>FAMA13G</b></p>
FAMA14	Cab Seating	Visible to operator inside the cab.  Fill in blank with number of belted seating positions.	2.0 x 3.0	14		<p><b>FAMA14G</b></p>
FAMA15	Helmet Worn in Cab	Visible from each seating location	2.0 x 3.0	10		<p><b>FAMA15G</b></p>
FAMA16	Deployable Steps	Visible at step locations.	2.0 x 3.0	14		<p><b>FAMA16G</b></p>





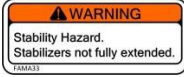



Ref Number	Hazard	Location	Size (in.)	Font Size	ANSI Version	ISO Version
FAMA17	Vehicle Backing	Visible to the driver while sitting in the driver seat.	2.0 x 3.0	9		 <p><b>FAMA17G</b></p>
FAMA18	Intake and Discharge Cap Pressure	One sign on each side and back of vehicle where caps are present.	3.5 x 3.5	12		 <p><b>FAMA18G</b></p>
FAMA19	Foam Type Mixing	Near Foam Controls	1.9 x 3.1	8		 <p><b>FAMA19G</b></p>
FAMA20	Ultra High Pressure Water	Visible to a person in front of the turret. Visible to turret operator. Visible to fire fighter preparing to use any hand line.	2.1 x 5.2	10		 <p><b>FAMA20G</b></p>

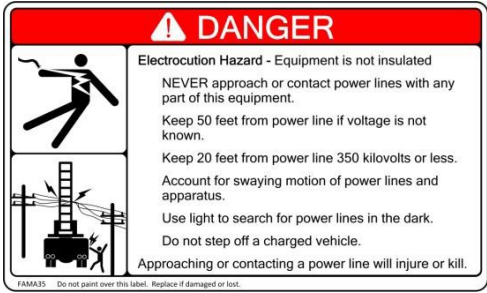

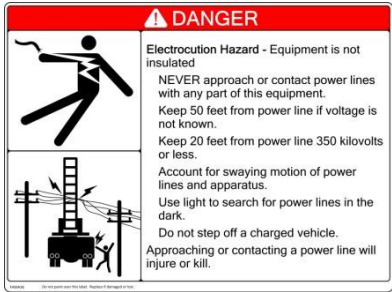









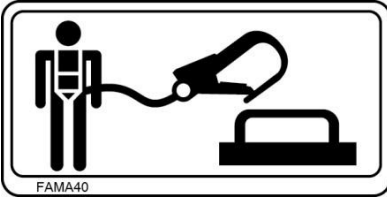





Ref Number	Hazard	Location	Size (in.)	Font Size	ANSI Version	ISO Version
FAMA21	Rotating or Swinging Parts	One sign near each crush point.	3.0 x 5.0	18		 <b>FAMA21G</b>
FAMA22	Hose Restraint Required	Near each hose storage area	1.9 x 3.1	10		 <b>FAMA22G</b>
FAMA23	Access Step Method - Small	Visible to personnel preparing to climb onto or enter vehicle.	3.5 x 3.5	10		 <b>FAMA23G</b>
FAMA24	Riding on exterior	On the vehicle at the rear step areas and at any cross walkways"	3.5 x 3.5	16		 <b>FAMA24G</b>
FAMA25	Trained Personnel Only - NFPA Required	Visible at pump operator's station and Aerial operator's platform. For apparatus without a pump or aerial device, locate this sign in a prominent location visible to operating personnel.	2.7 x 6.6	10		 <b>FAMA25G</b>



Ref Number	Hazard	Location	Size (in.)	Font Size	ANSI Version	ISO Version
FAMA26	No-Step	On any horizontal surface that would be tempting to step on but that is not provided with slip resistant surface and grab handles.	3.5 x 3.5	12		 <p><b>FAMA26G</b></p>
FAMA27	Breaker Box Warning	Visible to personnel accessing electrical panel.	1.9 x 3.1	8		 <p><b>FAMA27G</b></p>
FAMA28	Rope Tie-Down 9000	Near each rope anchor	1.9 x 3.1	8		 <p><b>FAMA28G</b></p>
FAMA29	Hydraulic High Pressure Leaks	One label per vehicle in a conspicuous area near the majority of the hydraulic lines or components.	3.0 x 5.0	10		 <p><b>FAMA29G</b></p>

Ref Number	Hazard	Location	Size (in.)	Font Size	ANSI Version	ISO Version
FAMA30	Stabilizer Crush	Visible to person standing near each stabilizer Visible to stabilizer deployment operator.	3.5 x 3.5	12		 <p><b>FAMA30G</b></p>
FAMA31	Stabilizer Pins & Pads	Visible to stabilizer deployment operator.	3.0 x 5.0	14		 <p><b>FAMA31G</b></p>
FAMA32	Stabilizer Pads	Visible to stabilizer deployment operator.	3.0 x 5.0	14		 <p><b>FAMA32G</b></p>
FAMA33	Stabilizers Not extended	Visible to stabilizer deployment operator.	0.9 x 2.1	10		 <p><b>FAMA33G</b></p>
FAMA34	Fall Restraint Required.	One sign near base of ladder. One sign visible in platform.	3.0 x 5.0	18		 <p><b>FAMA34G</b></p>

Ref Number	Hazard	Location	Size (in.)	Font Size	ANSI Version	ISO Version
FAMA35	Aerial Electrocutation Small Size	Visible to aerial and pump operator.	3.0 x 5.0	10		 <p><b>FAMA35G</b></p>
FAMA36	Aerial Electrocutation Large Size	Visible to personnel on aerial apparatus approaching vehicle from either side and back.	6.0 x 8.0	18		 <p><b>FAMA35G</b></p>
FAMA37	Aerial Device Load Capacity	Visible to aerial operator at turntable, in the platform, and at tip controls.	3.0 x 5.0	12		 <p><b>FAMA37G</b></p>
FAMA38	Aerial Ladder Rung Pinch	One sign visible to personnel operating tip controls. One sign visible to Aerial Operator.	1.9 x 3.1	10		 <p><b>FAMA38G</b></p>

Ref Number	Hazard	Location	Size (in.)	Font Size	ANSI Version	ISO Version
FAMA39	Aerial Inspection	Visible to operator at turntable.	2.0 x 3.0	10		 <p><b>FAMA39G</b></p>
FAMA40	Fall Protection Anchor	Next to fall protection anchor.	1.0 x 2.0			 <p><b>FAMA40G</b></p>
FAMA41	Cab Tilt	Inside of driver cab door	2.0 x 3.0	10		 <p><b>FAMA41G</b></p>
FAMA42	Siren Noise	Inside of driver cab door	2.0 x 3.0	9		 <p><b>FAMA42G</b></p>
FAMA43	Helmet Worn in Cab	Visible from each seating location	2.0 x 3.0	10		 <p><b>FAMA15G</b></p>

Ref Number	Hazard	Location	Size (in.)	Font Size	ANSI Version	ISO Version
FAMA44	Pump and Roll Fire Fighting Position - Exterior	One sign visible from the pump-and-roll firefighting position	3.5 x 3.5	14		
FAMA45	Pump and Roll Fire Fighting Position - Driver	One sign visible from the drivers position or visible to the driver while entering the cab	2.0 x 3.0	10		
FAMA46	Aerial Device Pinch	One sign on aerial device visible to personnel on the turntable at the foot of the device	1.9 x 3.1	10		

Ref Number	Hazard	Location	Size (in.)	Font Size	ANSI Version	ISO Version
FAMA47	Aerial Device Operator Attention Required	Visible to aerial operator at turntable, in the platform, and at tip controls	3.0 x 5.0	12		

**7 REVISIONS**

Date	Safety Sign	Description of Change
09/19/2013	FAMA30	Changed term from “jacks” to “stabilizers”. Added second pictograph panel for staying away from hazard. Changes made at the request of NFPA 1901/1906 Aerial Task Group.
09/19/2013	FAMA39	...daily, frequent, and annual inspections <u>and maintenance</u> . Change made at the request of NFPA 1901/1906 Aerial Task Group.
02/11/2014	FAMA13	Changed the graphics for consistency with W09 and J14 from SAE J2402. Increased font size from 8 to 10.
02/11/2014	FAMA16	Added deployable step symbol 2572 from ISO 7000. Increased font size from 12 to 14.
02/11/2014	FAMA40	Revised the image of the hook to be consistent with typical safety harness hooks.
02/11/2014	ISO Symbols	Added ISO text-free safety signs FAMA04G, FAMA06G, FAMA08G, FAMA09G, FAMA10G, FAMA11G, FAMA12G, FAMA13G, FAMA14G, FAMA16G, FAMA17G, FAMA19G, FAMA20G, FAMA21G, FAMA28G, FAMA36G, FAMA39G, FAMA40G, FAMA41G, and FAMA42G.
10/03/2014	FAMA44, 45	New NFPA 1906 Pump and Roll Fire Fighting Position signs.
10/03/2014	FAMA46	New pinch and crush warning sign for aerial device turntable position.
10/03/2014	FAMA47	New aerial primary operator attention required warning
04/07/2016	FAMA25	Added reference to NFPA 1962
04/07/2016	Table	Updated text and table to reflect changes due to the 2016 editions of NFPA 1901 and 1906